



Wheel Production Machine Series



FAR EAST MACHINERY CO., LTD.
Factory Automation Technology Co., Ltd.

Taiwan
Headquarter

www.FATEK.com.tw

T +886-5-213-3166 F +886-5-220-5293
global@femco.com.tw

621016
26, Chung-Shan Rd., Huo Le Village,
Ming-Hsiung, Chiayi County Taiwan.

FEMCO USA

+1(714) 898-2066
Sales@Femcousa.com

www.femcousa.com

Femco Inc
7142 Belgrave Avenue Garden Grove,
California, USA

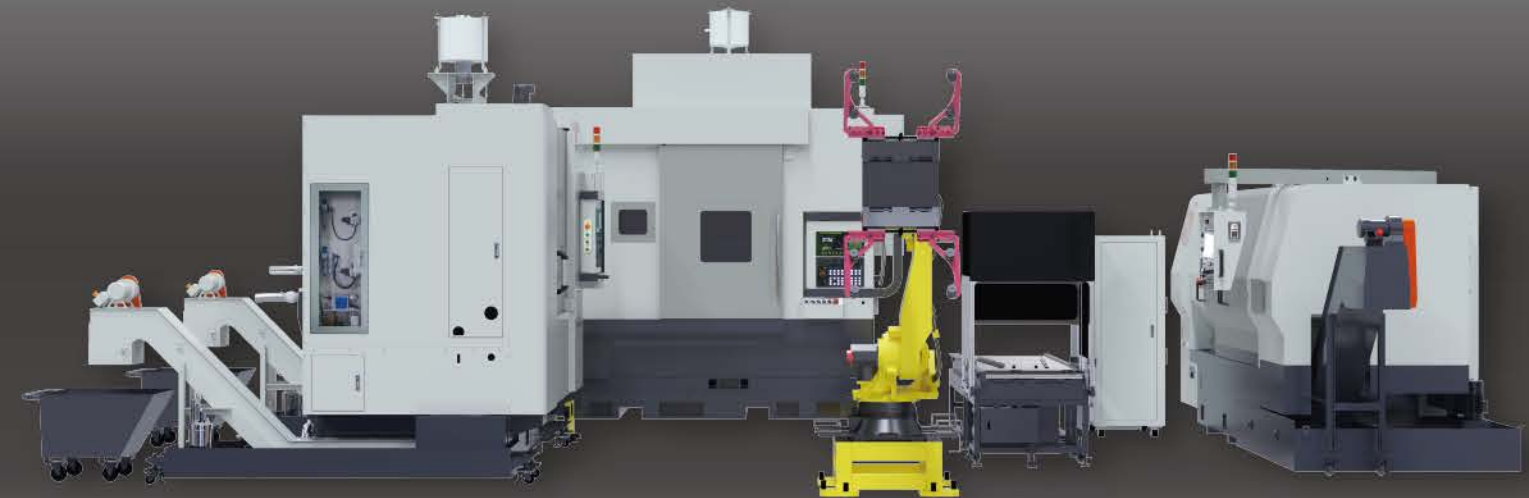

CNC WHEEL TURNING LATHE HORIZONTAL/VERTICAL/DRILLING TYPE



Horizontal Lathe Series



Available for Motorcycle / Automobile / Truck Wheel Turning Machine

WHL-55/68 High Speed Turning / Horizontal Wheel Turning Lathe

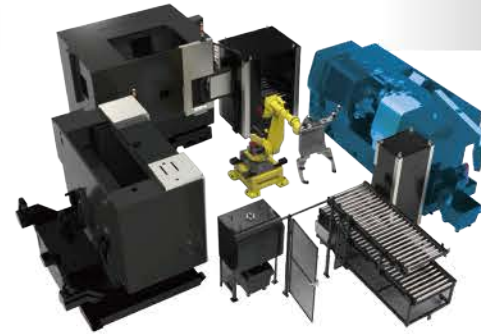

Appointed by High-Class Car
Dealerships Around the World

Designed for Processing
All-Size Wheels

Processing Features

1



Extra Wide Spindle

Main spindle specifically designed for wheels. Improved stability unmatched by generic CNC machining spindles.

2



Power Turret

Optional VDI40 power turret for 55(SP) series.

3



Servo Motor

High performance AC servo motor is directly connected to the ball screw for direct transmission system for synchronous axial transmission; beltless and gearless design reduce backlash and vibration; pretension ball screw provides minimum thermal deformation and high precision positioning of the working components.

4



Mirror Like Processing

SP series adopt C1 class ball screw which makes its scraping precision within Ra0.2.

5



High Frequency Treatment of Boxway

Casted X-slideway and machine body, high frequency thermal treatment, improved strength and resistance to wear for the slide-way, higher turning performance.

6



-This machine is equipped with complete automation peripheral equipment (robot arm signal communication device, control cabinet position sensor, chuck stroke sensor, and airproof sensor, etc.)

-We provide spindle box dynamic balance calibration before packaging to ensure the stabilization of processing.

WHL-55SP/68SP Professional Model for Mirror like Wheels

Mirror Like Turning
Exclusive Development

Scraping Precision
Within Ra0.2



Capacity	WHL-55	WHL-68	Spindle	WHL-55	WHL-68	Turret	WHL-55	WHL-68
X/Z-Axis Traverse	340/730 mm	360/850 mm	Rotational speed	2,500 rpm	2,500 rpm	Tool number	Servo 12/ servo 8(Optional)	Servo 12/ servo 8(Optional)
Standard Wheel Turning	20"	24"	Max torque	249/307 Nm	307/374 Nm	O.D turning tool size	□25 mm	25x32 mm
Standard Wheel Width	12"	12"	Motor power	30/37 kw	37/45 kw	I.D boring tool size	Ø50 mm	Ø63 mm
Max Turning Diameter	Ø620 mm	Ø680 mm						

Capacity	WHL-55SP	WHL-68SP	Spindle	WHL-55SP	WHL-68SP	Turret	WHL-55SP	WHL-68SP
X/Z-Axis Traverse	340/730 mm	360/850 mm	Rotational speed	2,500 rpm	2,500 rpm	Tool number	Servo 12/ servo 8(Optional)	Servo 12/ servo 8(Optional)
Standard Wheel Turning	20"	24"	Max torque	252/307 Nm	252/374 Nm	O.D turning tool size	□25 mm	25x32 mm
Standard Wheel Width	12"	12"	Motor power	37/45 kw	37/45 kw	I.D boring tool size	Ø50 mm	Ø63 mm
Max Turning Diameter	Ø620 mm	Ø680 mm						

Horizontal Lathe Series



Available for Motorcycle / Automobile / Truck Wheel Turning Machine

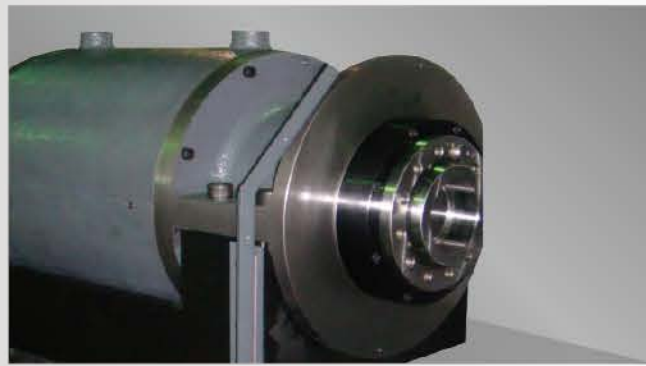

Built-In Spindle Motor (SP series only)

Eliminates noise and vibration from the belt, makes it not suffer from belt fatigue. Scraping precision within Ra0.2

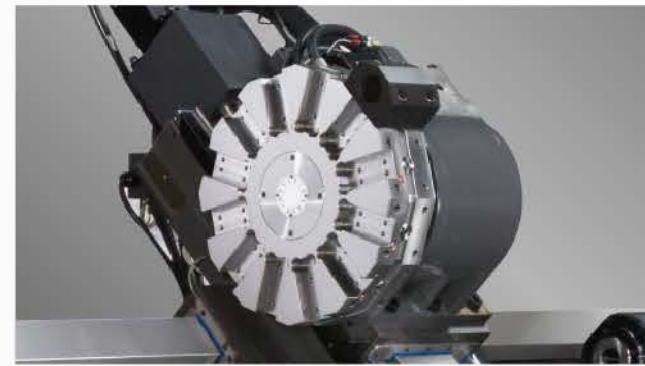

High Rigidity Servo Turret

■ Precise positioning, fast tool switching Tool switching time: 12 tools(standard)0.09 seconds 8 tools(optional)0.13 seconds
 ■ Turret can be equipped with accelerometer, which makes it able to collect vibration signal and work with the Internet.

WVL-T24/F24 Vertical Wheel Lathe

Motor Torque Output

WHL-55 Model αI 30/7000-B

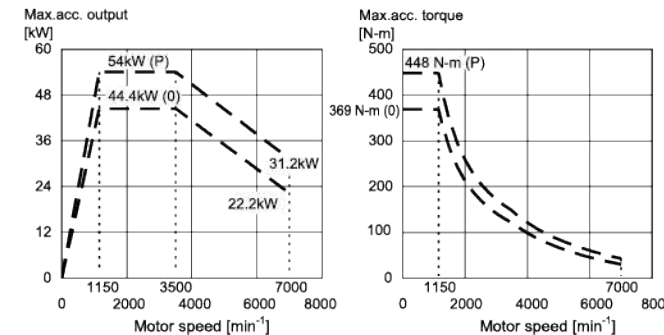
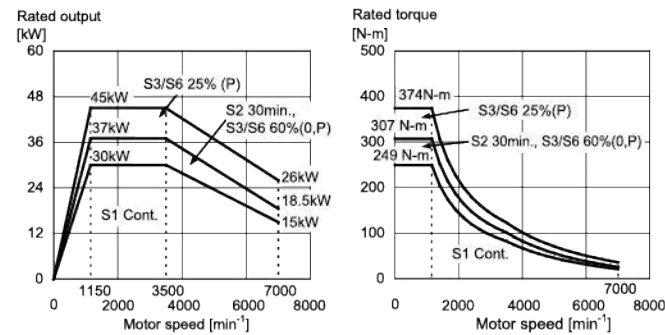

WHL-68 Model αI 40/7000-B

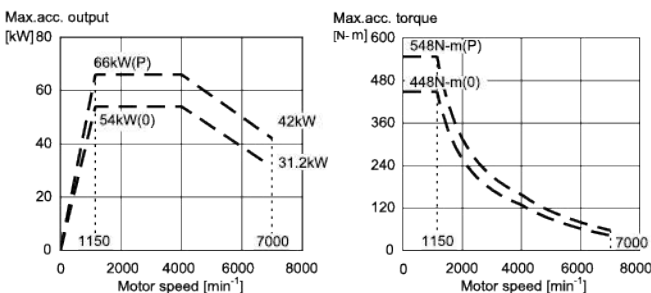
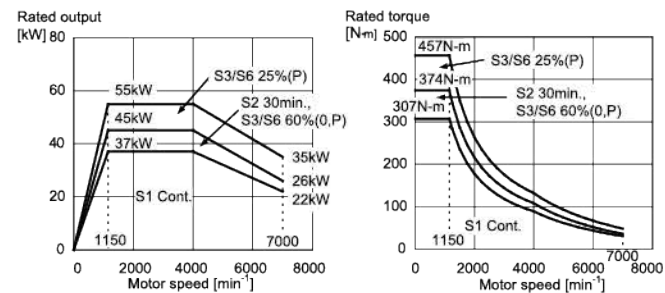

WHL-55/68SP Model βII 200M/6000-B

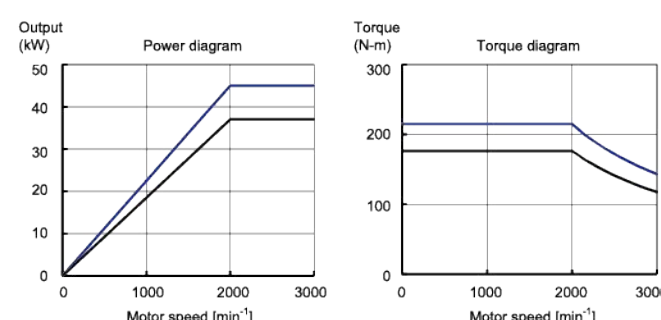
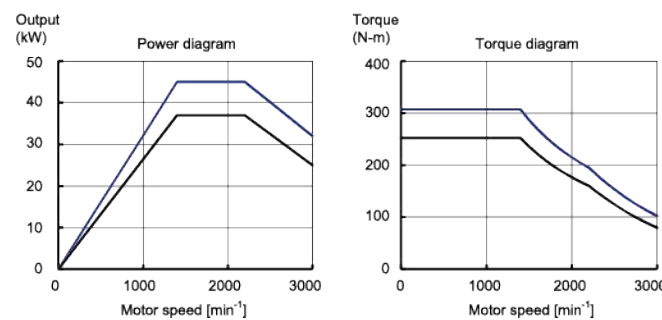

The Smallest Dimension with the Widest Processing Range of Sizes

Dual Turrets Design The Best Processing Efficiency

High Rigidity Structure The Best Table Loading

Exclusive High Rigidity Improve the Precision & Provide More Persistent Stability Spindle

Processing Features

1

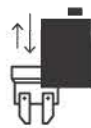

Servo Turret

High performance AC servo motor is directly connected to the ball screw for direct transmission system for synchronous axial transmission; beltless and gearless design reduce backlash and vibration; pretension ball screw provides minimum thermal deformation and high precision positioning of the working components.

2



Vertical Turret

Vertical servo turret paired with absolute coordinate system and high feed rate makes processing more efficient.

3



Coolant Through Tool Nose

We adopted advanced high-pressure coolant system through tool nose, which quickly flush chips and make processing much more stable.

4



Complete Integration

Integrate multiple filter options, like standard filter, paper tape filter, and rotary drum back washing filter, etc. it is flexible according to customers' needs.

5



**Standard/International VDI50*
Cutter Installation Interface**

We provide standard/international VDI50 cutter installation interface. It is more flexible and draw closer to customers.

-This machine is equipped with complete automation peripheral equipment (robot arm signal communication device, control cabinet position sensor, chuck stroke sensor, and airproof sensor, etc.)



Capacity	WVL-T24	WVL-F24
X/Z-Axis Traverse	480/650 mm	480/650 mm
Standard Wheel Turning	24"	24"
Standard Wheel Width	360 mm	360 mm
Max Turning Diameter	Ø720	Ø720

Spindle	WVL-T24	WVL-F24
Rotational speed	2,500 rpm	2,5000 rpm
Max torque	598 Nm	623 Nm
Motor power	37/45 kw	60/75 kw

Turret	WVL-T24	WVL-F24
Tool number	Single turret 6 (disc size 400mm)	Twin turret 6+6
O.D turning tool size/option	□ 25/32x25 mm	□ 25/32x25 mm
ID boring tool size	Ø63 / Ø50 / Ø40 mm	Ø63 / Ø50 / Ø40 mm



Motorcycle Wheel



Automobile Wheel



Truck Wheel

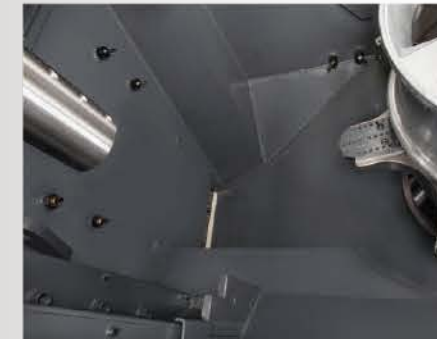

**Dual inclined bed type design (patent)
makes cleaning machine much easier.**



Dual turret provides high efficiency.



Fastest rapid traverse rate in the industry.



Double rear direct chip conveyor.

Motor Torque Output

WVL-F24

Model αII 60/5000HV-B

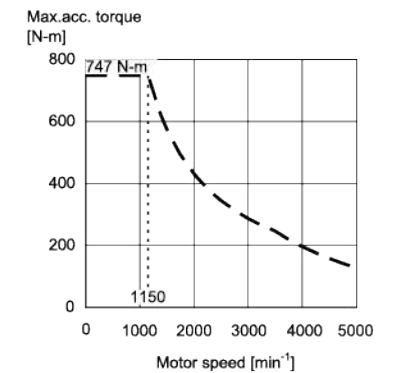
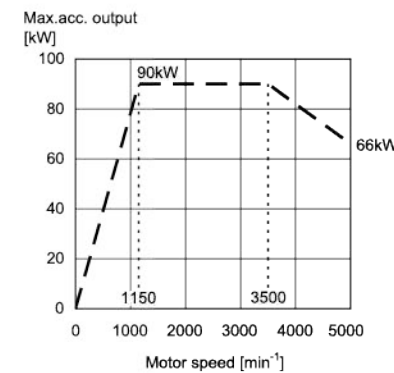
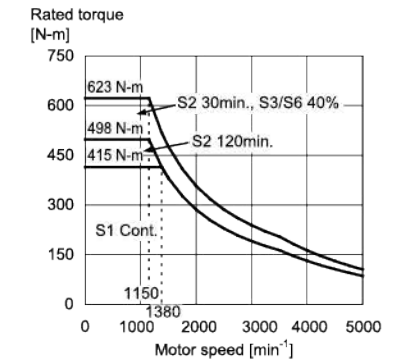
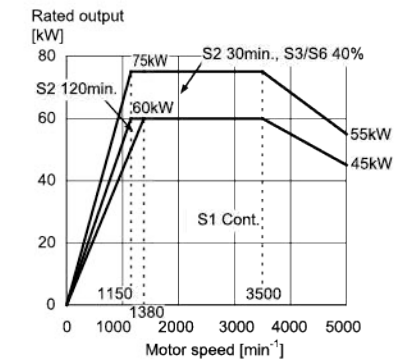

WVL-T24

Model αII 40/7000-B

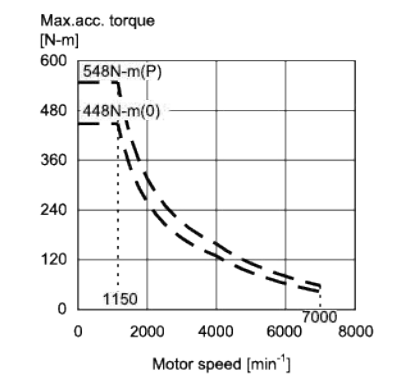
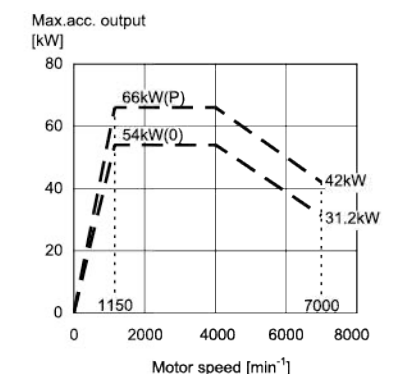
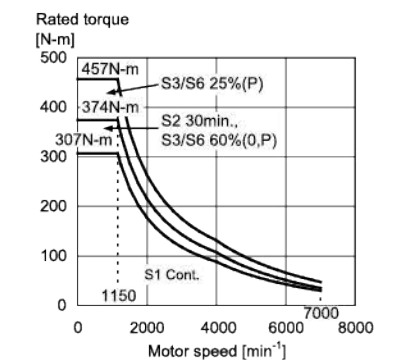
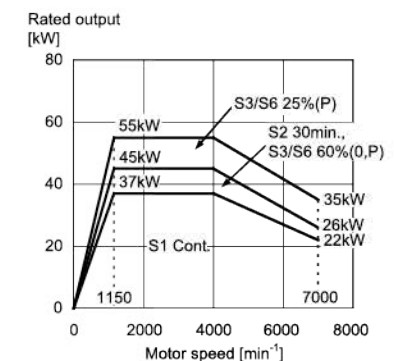

Wheel Drilling Series



Comprehensive Drilling Lathe WVD-24x / 24C

Exclusive High Rigidity Structure
Available for All Kinds of Wheels

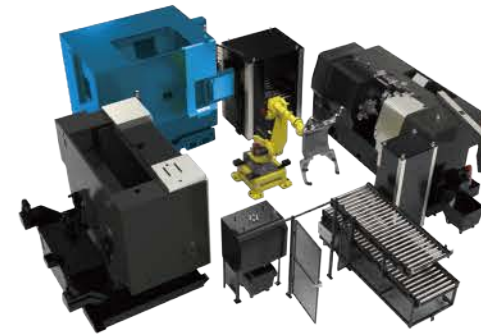

Simultaneous processing
Weight loss holes & PCD rear

Rotary Working Table
The Best Processing Efficiency

All-Size Processing Capacity
(13"~26")



Casting Wheels

Advanced Automotive Forging Wheels

Truck Forging Wheels

Comprehensive Turning Capacity

It is available for casting wheels, advanced automotive forging wheels, and truck forging wheels.



WVD-24x (Center Hole and Back Hole)

Industry first 180° rotary working table makes it available for processing weight loss hole and back boring within a procedure. It reduces the time of waiting & recalibration much and greatly improve precision & efficiency.

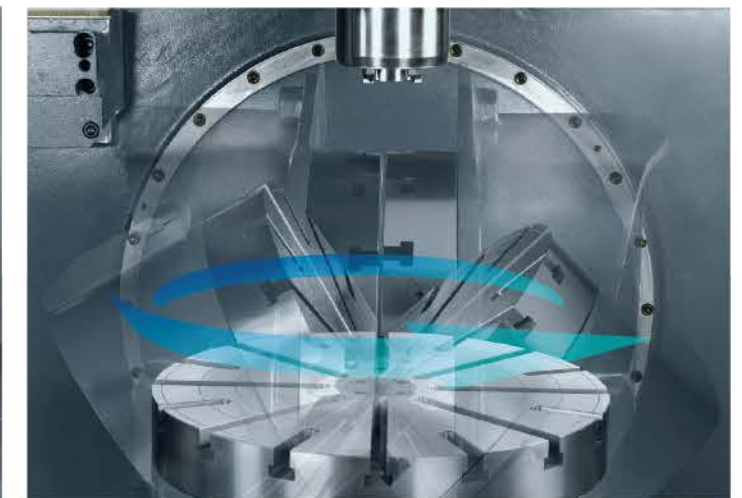

WVD-24C (Drilling)

According to various needs all around the world, we develop WVD-24C. With A28, A211 chuck, simultaneous 4 axis control & specific jig, this machine is available for back chamfering and tire pressure monitoring installation hole. It adjusts to various processing needs with its outstanding stability and capability.

Exclusive Strong Spray Chip System



Coolant Through System (optional)

Provides powerful coolant flushing capability, which is able to lubricate and cool the tools, reducing the possibility of tools getting wore and torn.

Automatic Spray Chip Device

The fixed wheels and the design of spray device from both left & right side of working table can help remove the chips automatically which reaches the automation required standard.

Exclusive Center Hollow Out Jig (24x only)

Exclusive center hollow out jig and inclined bed keep chips out of machines and make it the most efficient one in industry.

World First Exclusive **Multiple Patents** Efficiency NO.1 / Chip Removal NO.1 / Quality NO.1

Working Diagram

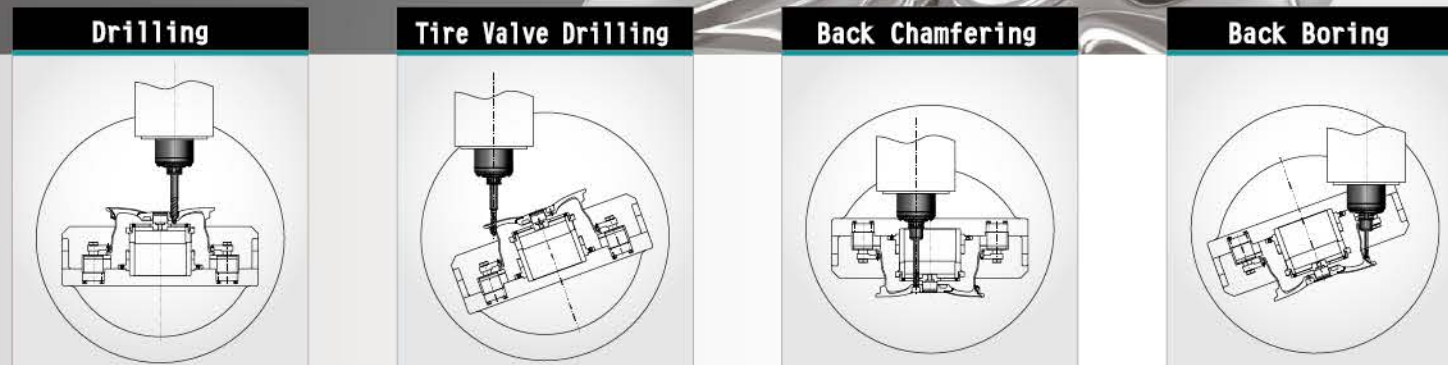

Processing Features

- 1 **All-Size Processing**
WVD-24C Type C with C axis gives customer more flexible capacity.
- 2 **5 Axis Turning & Milling**
5 axis design makes WVD-24C can handle complex processing, reduce the time of processing.
- 3 **Rotary Working**
Exclusive rotary working table design makes it possible to rotate parts. with B axis & C axis function, the turning process becomes much more efficient.

- 4 **Improve Efficiency**
With servo motor, it improves feed rate up to 48m/min and reduces time of processing a lot compared to traditional
- 5 **High Speed Spindle Capacity**
RPM of the high-speed servo spindle is up to 15000 which can be applied to variety of hole processing.
- 6 **Rapid Tool Change**
With ATC & absolute coordinate system, the machine can change tools quickly and make processing more efficient.

This machine is equipped with complete automation peripheral equipment (robot arm signal communication device, control cabinet position sensor, chuck stroke sensor, and airproof sensor, etc.)



Capacity	WVD-24x	WVD-24C	Spindle	WVD-24x	WVD-24C	ATC System	WVD-24x	WVD-24C
X/Z-Axis Traverse	855/547/500 mm	855/547/500 mm	Rotational speed	8,000~15,000 rpm	8,000~15,000 rpm	Tool number	24/40ATC	24/40ATC
Standard Wheel Turning	24"	24"	Max torque	α22(140)	α22(140)	O.D turning tool size	72/80 mm	72/80 mm
Standard Wheel Width	26"	26"	Motor power	α22(22/26)	α22(22/26)	ID boring tool size	300 mm	300 mm
Max Turning Diameter	800x800 mm	Ø630 mm						

Smart Automation

Intelligent aluminum wheel rim production line **WHL / WVL / WVD**



3 Persistence • Build the Best Brand in Chinese Market

A. Flexible Layout

B. Complete Integration

C. Smart Application

DEVICE INTEGRATION MONITORING SYSTEM

We provide the most comprehensive smart production & key solution for our customers with industrial internet of things, applications, augmented reality and software/hardware integration to help customers do digital transformation, improve production efficiency, optimize quality, and step forward to smart manufacturing.



- 
Grasp All the Information of Production
 Customers are able to monitor the data of the whole processing which allow customers to improve production efficiency and reduce the costs.
- 
Real Time Telemonitoring
 There is no restriction to time and places of monitoring the whole factory.
- 
Abnormal Alarm
 Whenever there is abnormal situation, customers will be notified by mail or communication software.
- 
Device Data Collection
 The operation condition & alarm will be collected and reported to improve device efficacy and optimize the whole production line.



Whole Production Line Monitoring

- The device status of whole production line:**
 - Statistics of all device running status: running, disconnection, alarm, emergency stop, standby, stop, manual mode, and warm-up.
 - Customers can click the "status" button to inspect the information of devices.
- Activation of whole production line:** we use colors to label different alarm (green: normal, orange: alarm, red: alarm)



Information of Single Machine

- Basic information:**
 - Work order: name of workpiece, stock number, processing code, processing time, amount of processing, number of spindle tool, rpm of spindle, rpm of spindle motor, and feed rate.
 - Activation: spindle load is labeled by different colors (green: normal, orange: alarm, red: alarm)
- Device status:** running, disconnection, alarm, emergency stop, standby, stop, manual mode, and warm-up.



Abnormal Alarm

Whenever there is abnormal situation, customers will be notified by mail or communication software.



Running Record of Single Machine

- Pie chart of running status**
- Transition diagram**
- Processing record:** time, duration, processing code, amount of processing, notation, etc.



Whole Production Line Running Record

- Pie chart of running status**
- Transition diagram**
- Processing record:** time, duration, processing



Maintenance

Customers can maintain machines following the instruction animation.

TOOL INTERFERENCE

WHL-55 / 55SP

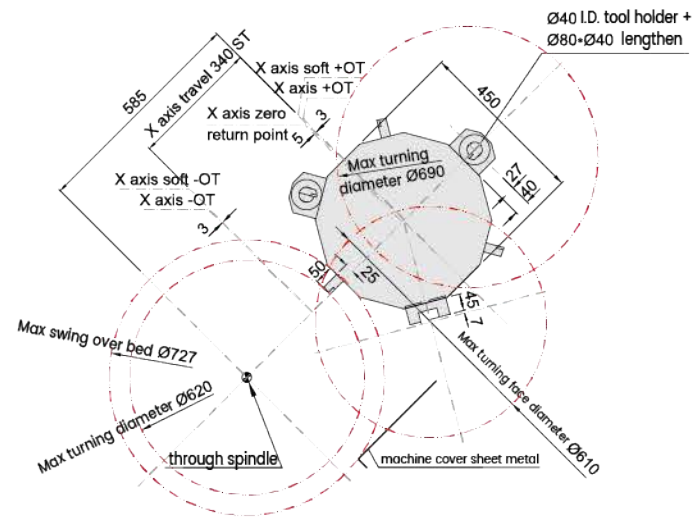

WHL-68 / 68SP

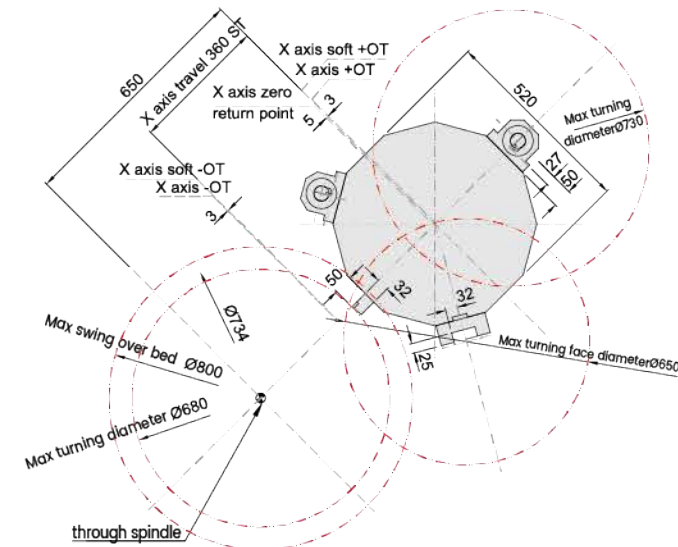

WVL-F24

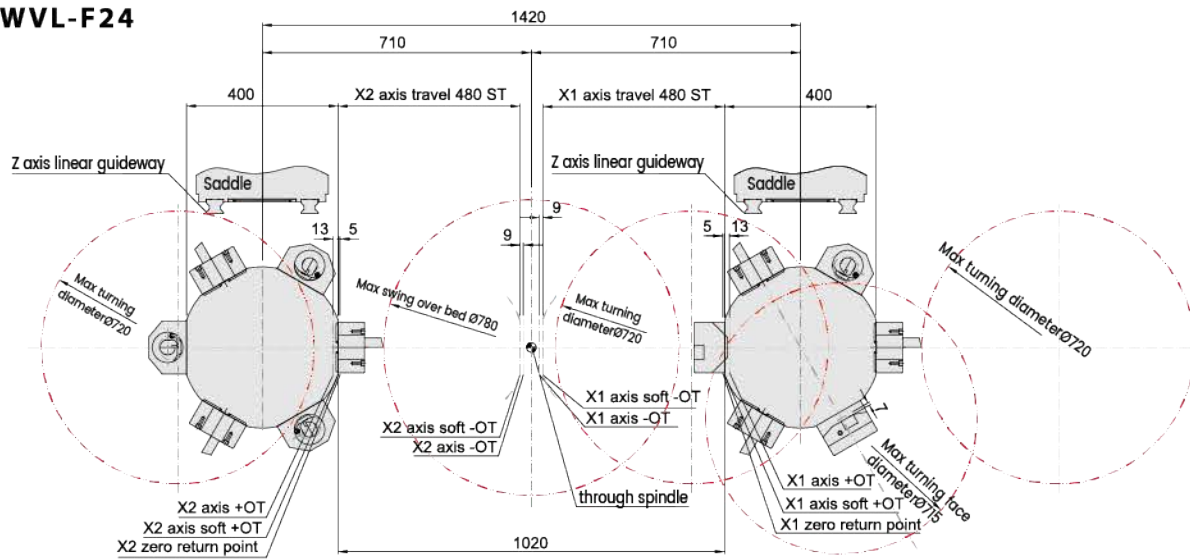

WVL-T24

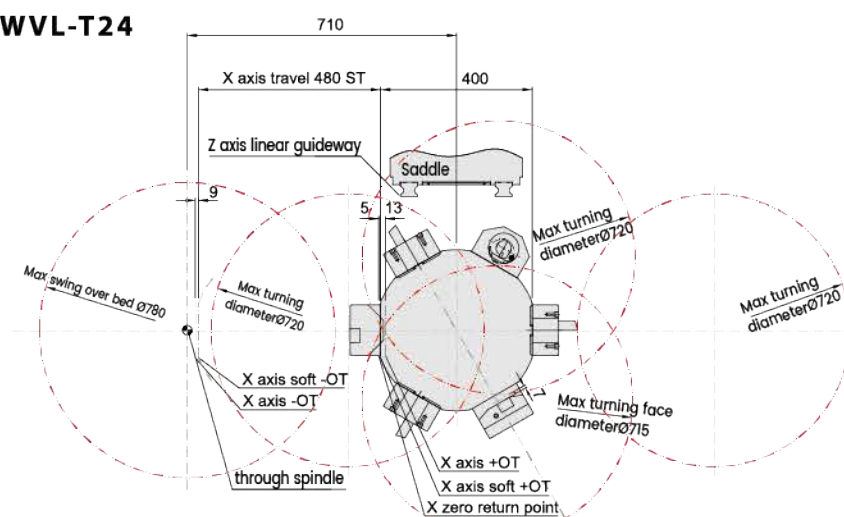

TOOL MOVEMENT

WHL-55 / 55SP

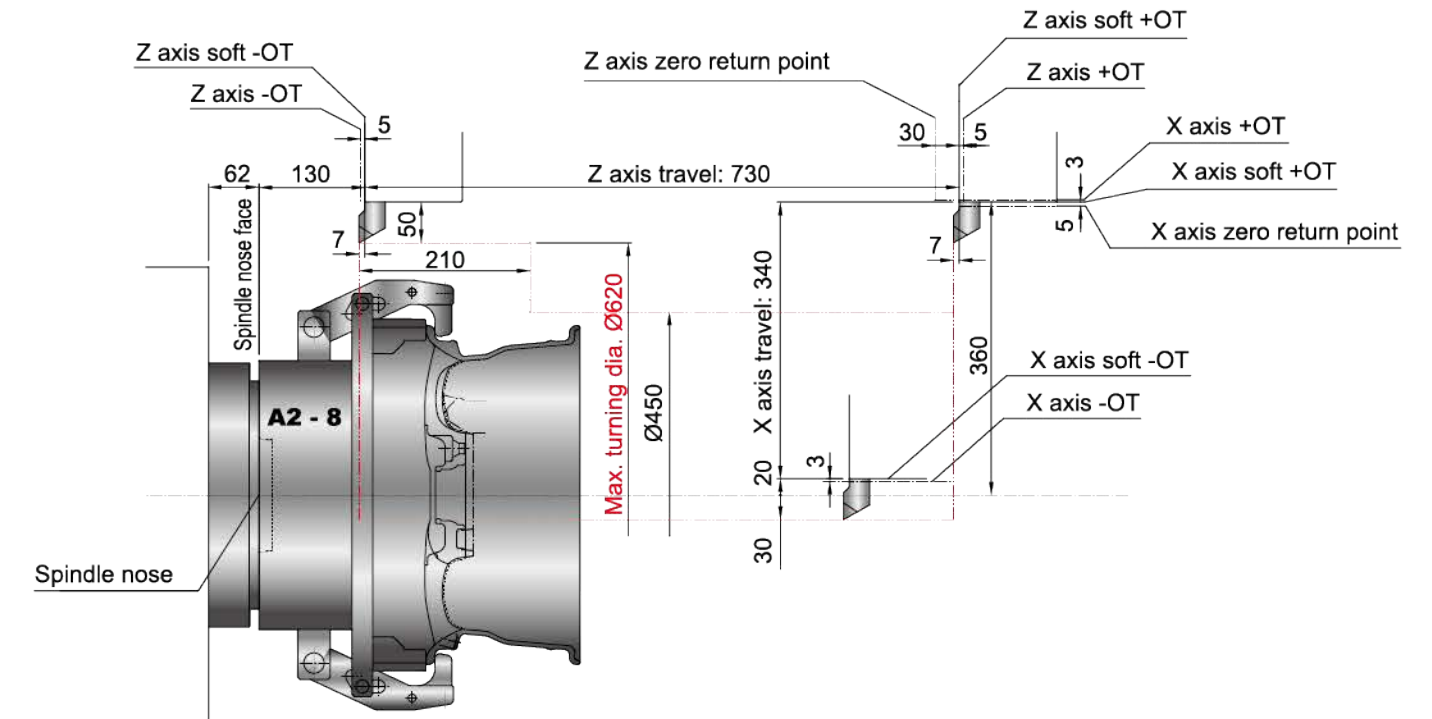

WHL-68 / 68SP

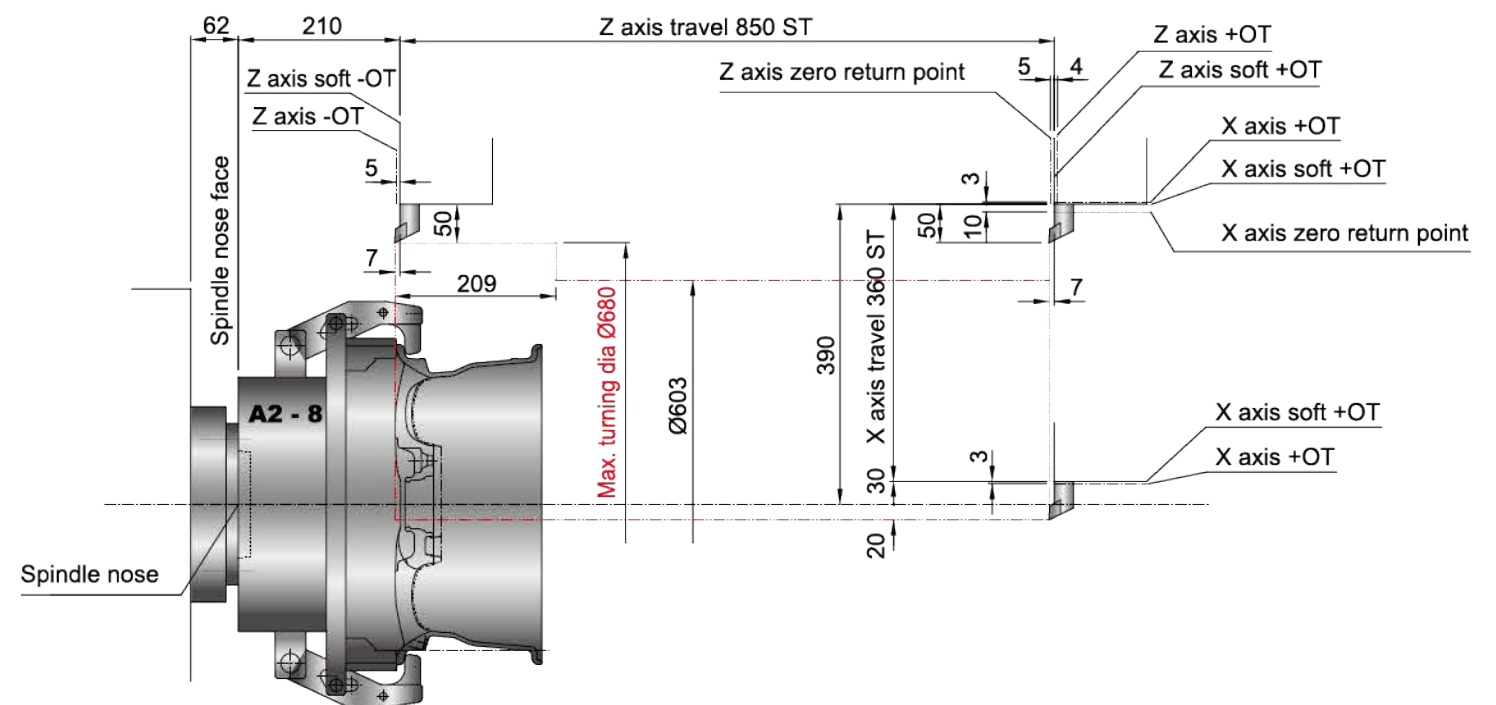

TOOL INTERFERENCE

WVL-F24

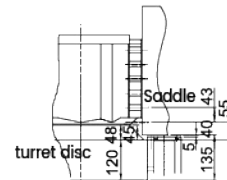
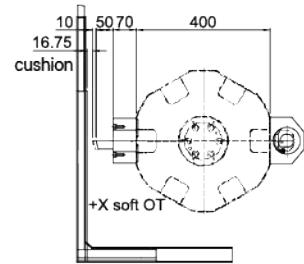

drawing of distance from turret disc to slide way end face.

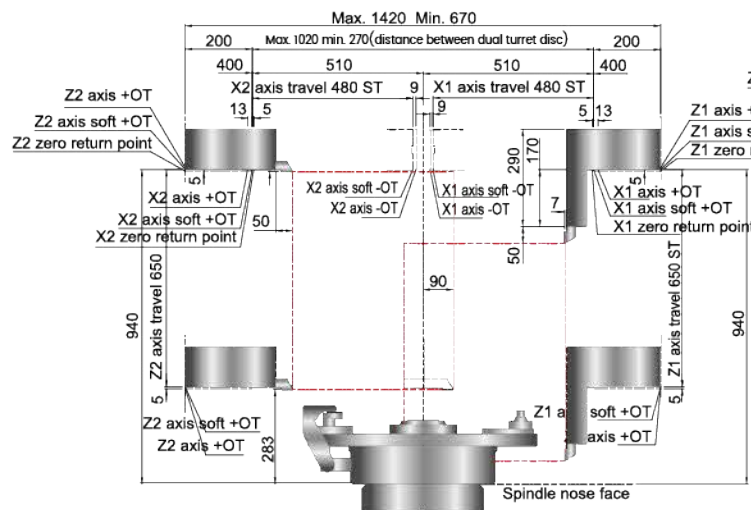

drawing of O.D. tool and facing tool movement

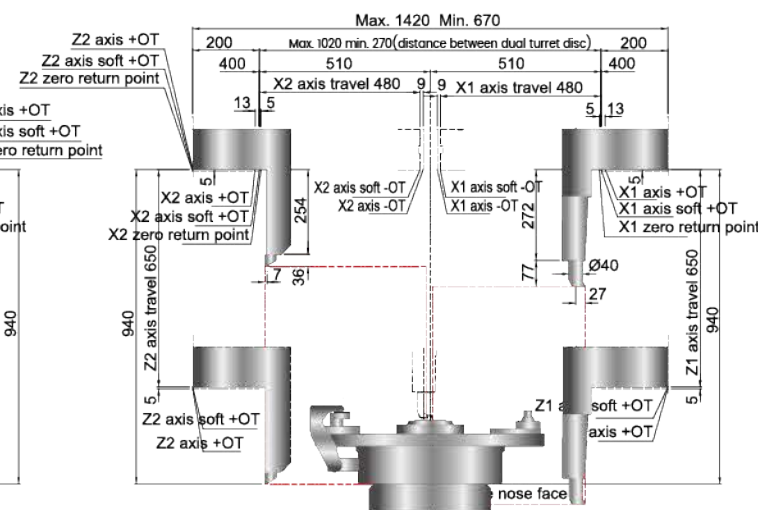

drawing of I.D. Boring and inner tool stroke

WVL-T24

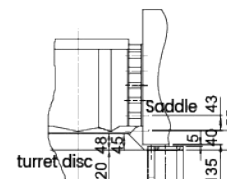
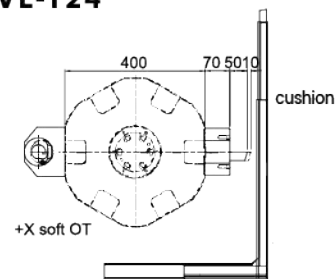

drawing of distance from turret disc to slide way end face.

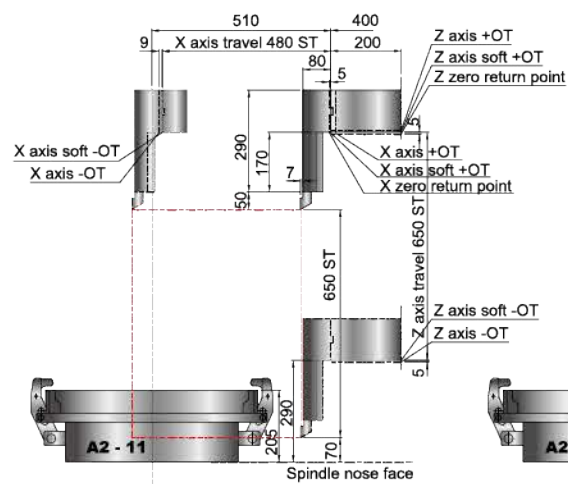

drawing of Single turret facing tool movement

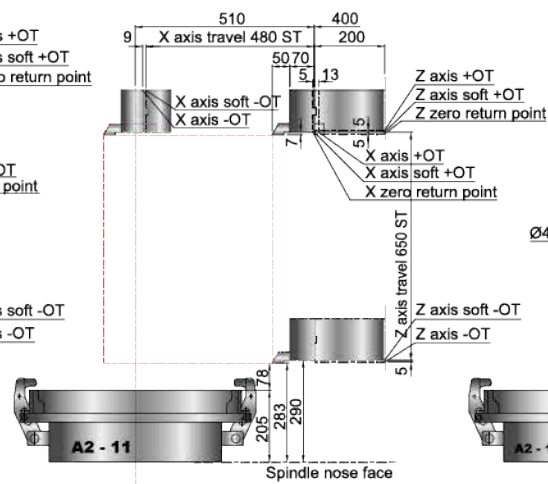

drawing of Single turret O.D. tool movement

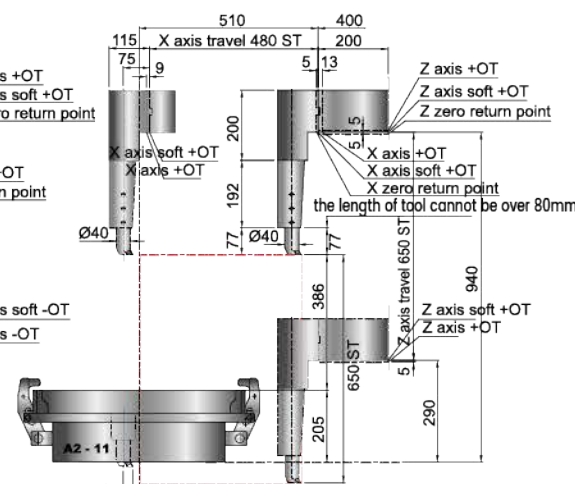

drawing of Single turret I.D. boring movement

WVD-24x

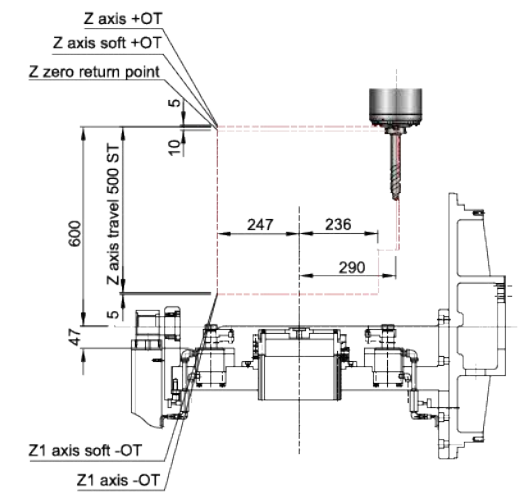
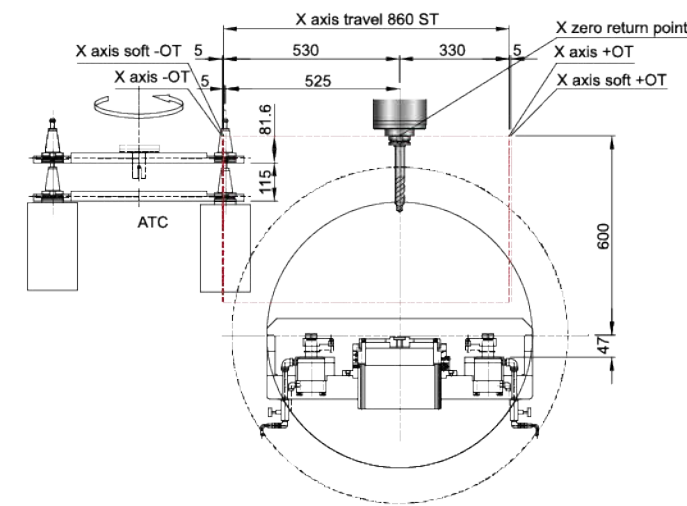
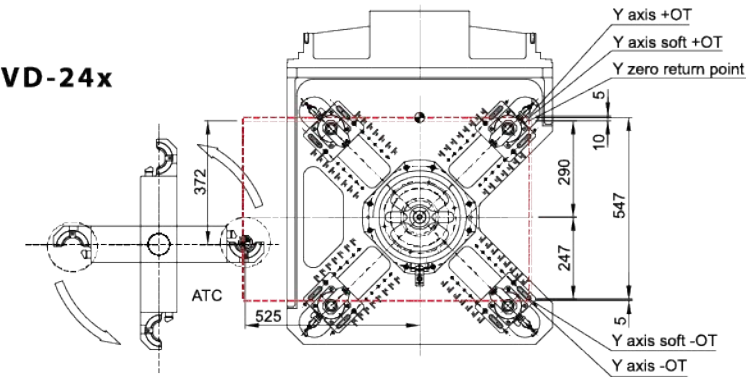

WVD-24C

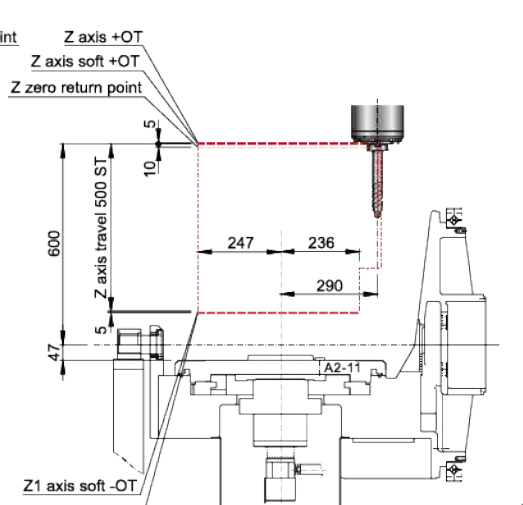
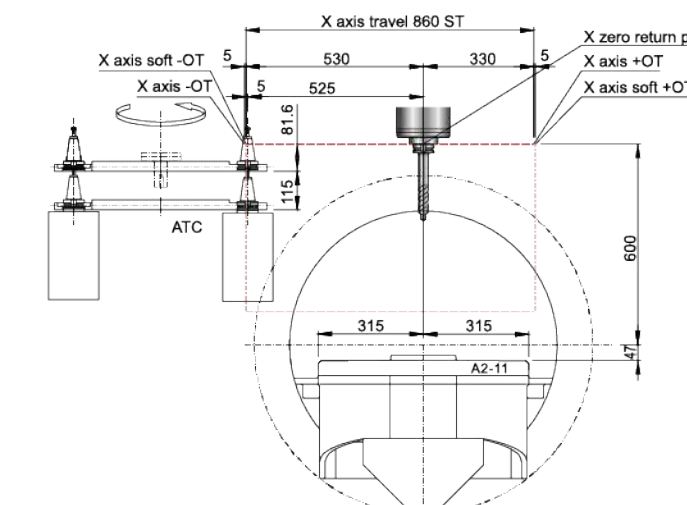
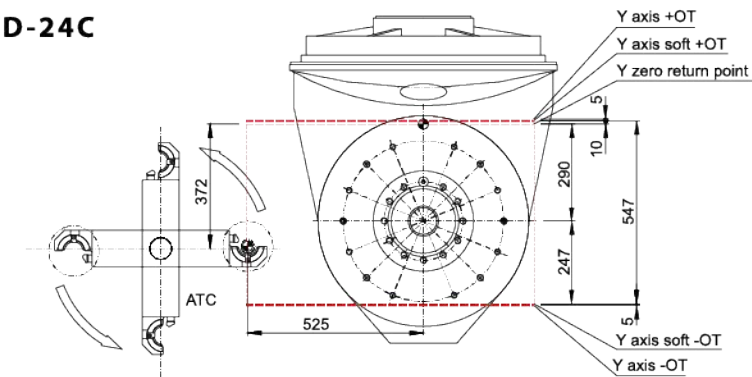

EXTERNAL DIMENSION

WHL-55/55SP

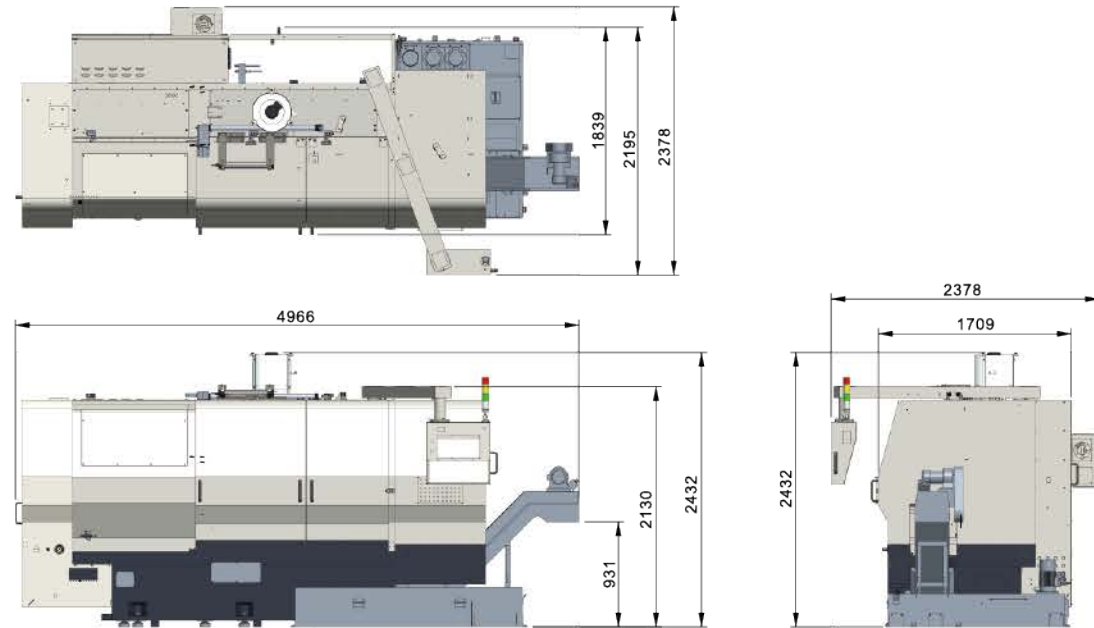

WHL-68/68SP

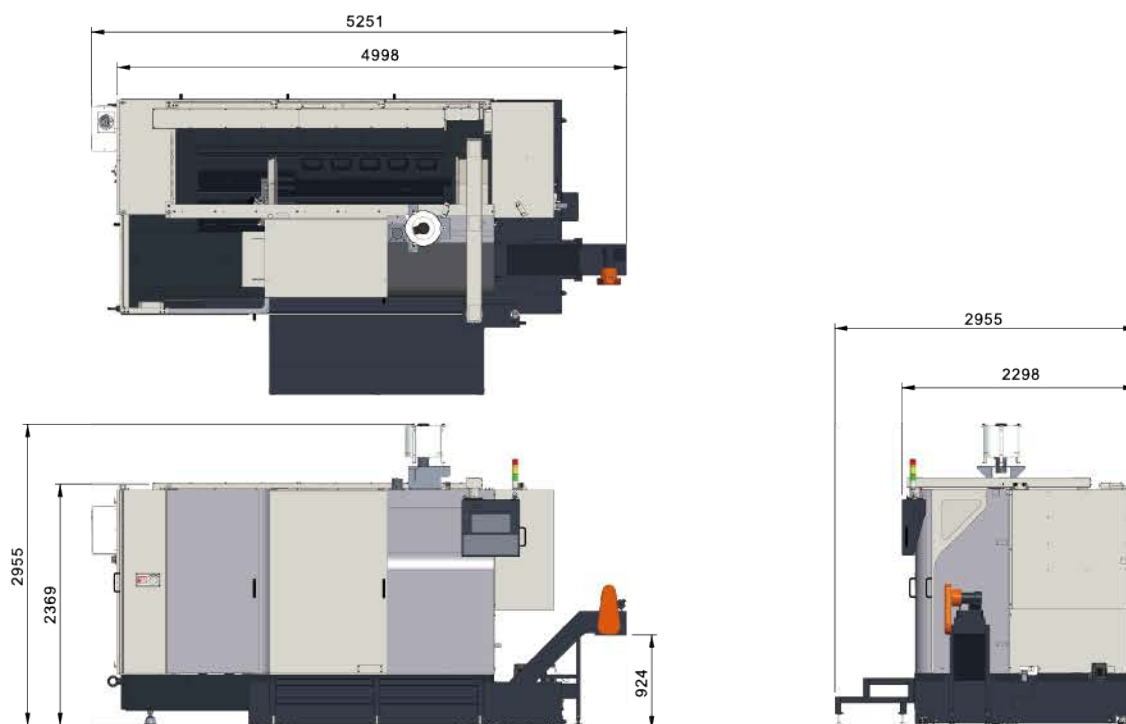

WVL-F24

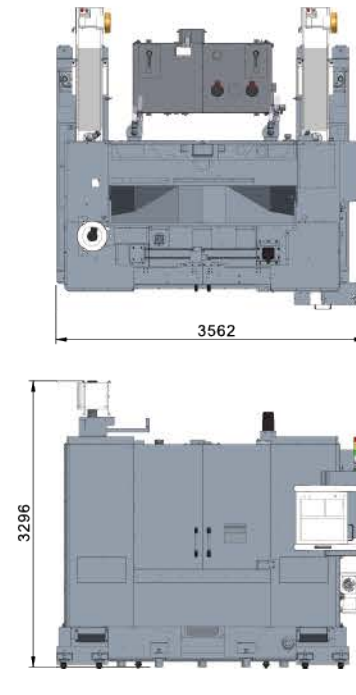

WVL-T24

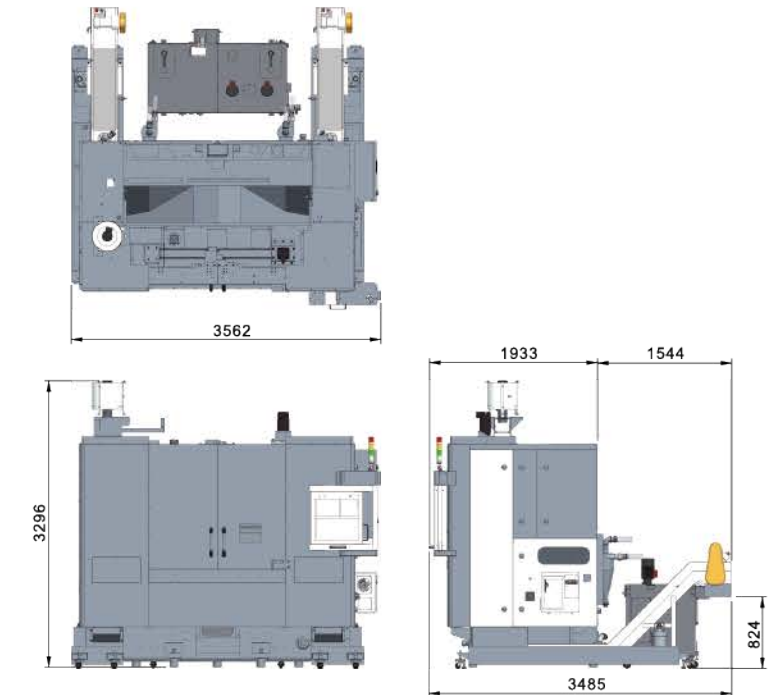

WVD-24x/24C

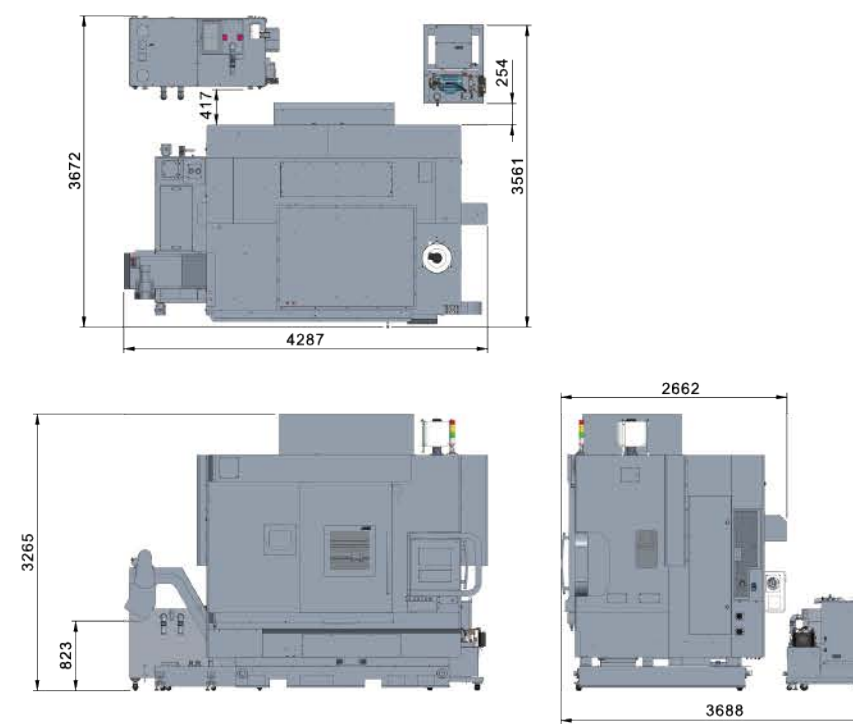

SPECIFICATIONS

ITEM	UNIT	WHL-55	WHL-55SP	WHL-68	WHL-68SP	WVL-T24	WVL-F24	WVD-24x	WVD-24C
PROCESSING CAPACITY	Max turning diameter	mm	Ø620	Ø620	Ø680	Ø680	Ø720	Ø720	-
	Max turning height	mm	-	-	-	-	360	360	-
	Max swing over bed	mm	Ø727	Ø727	Ø800	Ø800	Ø780	Ø780	-
	Standard wheel turning	inch	20	20	24	24	24	24	24
	Max wheel turning (optional)	inch	-	-	-	-	26	26	26
	Max wheel width	inch	12	12	12	12	12	12	12
	Workstation size	mm	-	-	-	-	-	-	800x800
	Max load	kg	-	-	-	-	-	-	300
STORKE	X-axis	mm	340 (-335/+5)	340 (-335/+5)	360 (-350/+10)	360 (-350/+10)	480 (-475/+5)	480 (-475/+5)	855 (-525/+330)
	Y-axis	mm	-	-	-	-	-	-	547 (-537/+10)
	Z-axis	mm	730 (-700/+30)	730 (-700/+30)	850 (-845/+5)	850 (-845/+5)	650 (-645/+5)	650 (-645/+5)	500 (-490/+10)
	B-axis	deg	-	-	-	-	-	-	-95°~185°
	C-axis	deg	-	-	-	-	-	-	-
	Distance from spindle nose to workstation	-	-	-	-	-	-	-	713
SPINDLE	Rotating speed	rpm	2500	2500	2500	2500	2500	2500	8000~15000
	Nose type	-	A2-8	A2-8	A2-8	A2-8	A2-11	A2-11	Taper hole ISO. 40/BT40/CAT40
	Front end bearings I.D/O.D	mm	Ø130/Ø200	Ø130/Ø200	Ø130/Ø200	Ø130/Ø200	Ø160/Ø240	Ø160/Ø240	Ø70/Ø110
	Rear end bearings I.D/O.D	mm	Ø120/Ø180	Ø120/Ø180	Ø120/Ø180	Ø120/Ø180	Ø140/Ø210	Ø140/Ø210	Ø70/Ø110
	Motor type (C.T.S)	FANUC	α30/7000	BiI200M/6000	α40/7000i	BiI200M/6000	α40i/7000	α60i/5000HV	α22iT (10000)
	Motor type (without C.T.S)	-	-	-	-	-	-	-	-
	Motor power (continuous/30min)	kW	30/37	37/45	37/45	37/45	37/45	60/75	α22 (22/26)
	Max torque	Nm	249/307	252/307	307/374	252/307	598	623	α22 (140)
TURRET/A.T.C	Tool number	POS	Servo 12/*Servo 8	Servo 12/*Servo 8	Servo 12/*Servo 8	Servo 12/*Servo 8	Servo singal turret 6 tools	6+6	24/40 ATC
	O.D turning tool size	mm	□25	□25	□25x32	□25x32	□25 / 32x25(option)	□25 / 32x25(option)	-
	I.D boring tool size	mm	Ø50	Ø50	Ø63	Ø63	Ø63 / Ø50 / Ø40	Ø63 / Ø50 / Ø40	-
	Shank taper	-	-	-	-	-	-	-	ISO.40/BT40/CAT40
	Pull studs	-	-	-	-	-	-	-	7388/2-B/MAS407/ANSI (CAT)
	Max tool length	mm	-	-	-	-	-	-	300
	Max tool size	mm	-	-	-	-	-	-	72/80 (Tool O.D)
	Max tool load	kg	-	-	-	-	-	-	8
	Tool switching time	sec	0.09/0.13	0.09/0.13	0.15/0.09	0.15/0.09	-	-	1.47
	1.47	1.47	1.47	1.47	1.47	1.47	1.47	1.47	1.47
SERVO MOTOR	X-axis	kW	4	4	4	4	4	4	3
	Y-axis	kW	-	-	-	-	-	-	3
	Z-axis	kW	4	4	4	4	4	4	4
RAPID TRAVERSES	X-axis (x1/x2)	mm/min	16000	16000	16000	16000	36000	36000	48000
	Y-axis	mm/min	-	-	-	-	-	-	48000
	Z-axis (z1/z2)	mm/min	20000	20000	20000	20000	36000	36000	48000
BALLSCREW OD AND THREAD	X-axis	mm	Ø36xP8	Ø36xP8	Ø36xP8	Ø36xP8	Ø50xP12	Ø50xP12	Ø36xP16
	Y-axis	mm	-	-	-	-	-	-	Ø36xP16
	Z-axis	mm	Ø50xP12	Ø50xP12	#Ø50xP10	#Ø50xP10	Ø50xP12	Ø50xP12	Ø36xP16
TRAVERSE RATE	Max turning traverse rate (x/y/z)	mm/min	-	-	-	-	10000	10000	10000
TURNING FLUID UNIT	Pump	Tool cooling	kW	0.58(50Hz)/0.9(60Hz)	0.58(50Hz)/0.9(60Hz)	0.58(50Hz)/0.9(60Hz)	0.58(50Hz)/0.9(60Hz)	1.3(50Hz)/1.42(60Hz)	1.3(50Hz)/1.42(60Hz)
	(submersion type)	Turning washing	kW	2.14(50Hz)/2.8(60Hz)	2.14(50Hz)/2.8(60Hz)	0.58(50Hz)/0.9(60Hz)	0.58(50Hz)/0.9(60Hz)	1.3(50Hz)/1.42(60Hz)	1.3(50Hz)/1.42(60Hz)
	Water tank volume	Liters	450	450	800	800	1200	1200	260(major)/10000(minor)
HYDRAULIC UNIT	Pump	kW	1.5	1.5	2.2	2.2	1.5	1.5	1.5
	Oil tank volume	Listers	44	44	55	55	47	47	47
LUBRICATION UNIT	Pump	W	30	30	30	30	30	30	30
	Oil tank volume	Liters	4	4	4	4	4	4	4
MACHINE EXTERIOR (EXCLUDING CHIP CONVEYOR)	Width	mm	4105	4105	4800	4800	3420	3420	4200
	Depth	mm	2570	2570	2600	2600	2493	2490	2670
	height	mm	2440	2440	2456	2456	3320	3320	3200(Without oil-mist collector)/3270(With Oil-mist collector)
MACHINE WEIGHT	Weight	kg	9000	9000	10500	10500	11000	11000	9000/12,000(Support base of front worktable is included)
POWER CAPACITY		KVA	65	65	70	70	70	100	55
CONTROL SYSTEM			FANUC Oi-TF+	FANUC Oi-TF+	FANUC Oi-TF+	FANUC Oi-TF+	FANUC Oi-TF+	FANUC Oi-TF+	FANUC Oi-MF+

• Design and specifications are subject to change without prior notice.

STANDARD & OPTIONAL ACCESSORIES

● STANDARD ○ OPTION × INCOMPATIBLE

ITEM	WHL-55	WHL-55SP	WHL-68	WHL-68SP	WVL-T24	WVL-F24	WVD-24x	WVD-24C
6-tool(turret)	X	X	X	X	●*1	●*2	X	X
8-tool(turret)	○	○	○	○	X	X	X	X
12-tool(turret)	●	●	●	●	X	X	X	X
VDI Turret	X	X	X	X	○	○	X	X
Hydraulics unit	●	●	●	●	●	●	●	●
Automatic lubrication system	●	●	●	●	●	●	●	●
I.D boring tool holder and sleeve	●	●	●	●	●	●	X	X
O.D turning tool holder	●	●	●	●	●	●	X	X
Work lamp	●	●	●	●	●	●	●	●
Leveling bolts and washers	●	●	●	●	●	●	●	●
Operation/Maintenance/Electical/Parts manual	●	●	●	●	●	●	●	●
Automatic chips spray device	●	●	●	●	●	●	●	●
Counter (built-in)	●	●	●	●	●	●	●	●
Heat exchanger	●	●	●	●	●	●	●	●
Chip conveyor and bucket	●	●	●	●	●	●	●	●
FANUC operator manual	●	●	●	●	●	●	●	●
Safety automatic door	●	●	●	●	●	●	●	●
Built-in spindle motor	X	●	X	●	X	X	X	X
External testing device	X	X	X	X	X	X	X	X
C1 class ball screw	X	●	X	●	X	X	X	X
Cooling system	●	●	●	●	●	●	●	●
Transformer	○	○	○	○	○	○	○	○
Finger chuck (WHL)	○	○	○	○	○	○	●	○
Granite headstock	X	○	X	○	X	X	X	X
Horizontal level adjuster	○	○	○	○	○	○	○	○
Oil skimmer	●	●	●	●	●	●	●	●
Counter (external)	●	●	●	●	●	●	●	●
Three color indicator	●	●	●	●	●	●	●	●
Electrical air conditioner	○	○	●	●	●	●	●	●
CE safety wall	○	○	○	○	○	○	○	○
Production line planning service	○	○	○	○	○	○	○	○
B-axis support base	X	X	X	X	X	X	●	○
Wheels drilling clamping jig	X	X	X	X	X	X	●	●
ATC magazine (24 tools)	X	X	X	X	X	X	●	●
Spindle speed 10000r.p.m (standard)	X	X	X	X	X	X	●	●
Coolant through spindle system	X	X	X	X	X	X	●	●
Spindle speed 12000/15000r.p.m (option)	X	X	X	X	X	X	○	○
Machine automatic measurement system	○	○	○	○	○	○	○	○
Automation human-computer interface	○	○	○	○	○	○	○	○
Articulated robotic arm	○	○	○	○	○	○	○	○

● Design and specifications are subject to change without prior notice.

OPTIONAL ACCESSORIES



Professional Production Line Planning

Guidance and planning based on different production requirements, cost considerations, and manufacturing conditions.



Granite Headstock

Granite headstock is optional for absorbing vibrations from spindle better and improve stability.



Air Conditioning for Electrical Panel

High performance cooling system for maintaining constant internal temperature of electrical panel. (Prices vary from different brands an models)



Transformer

220V / 380V / 415V / 440V



Robot Arm

Robot arm can be connected to machines for automatic system.



CE Safety Wall

CE Safety Wall